

# Aqua-Vu®



## CLAW

Underwater Viewing and  
Retrieval System  
Owners Manual

## Table of Contents

Become an Underwater Explorer .....	4
In Your Package.....	5
About Your Aqua-Vu System .....	6
Product Safety .....	6
Using the Stabilizing Fin .....	6
Powering the Your Aqua-Vu System.....	6
Battery Care .....	7
Over Charging .....	7
Under Charging.....	7
Using the Aqua-Vu Controls .....	7
Viewing Images on the Monitor .....	7
Charging the Battery.....	8
Monitor Menu Functions.....	8
Frequently Asked Questions .....	9
Troubleshooting.....	10
Warranty Information .....	11
One Year Limited Warranty.....	11
How to Obtain Service .....	11

## Become an Underwater Explorer

Congratulations! Your new Aqua-Vu Underwater Viewing and Retrieval System allows you to become an aquatic explorer without getting wet! From a boat or pier, watch the underwater world on your Aqua-Vu's monitor as you swim the fish camera over the bottom landscape. Or, with camera lowered through a hole in the ice, see how approaching fish react to your bait!

However you employ your Aqua-Vu — as a serious fishing tool on open-water or on ice; for observing and learning about nature; for watching small children or pets; or for security purposes — you will experience a fascinating new real-life view!

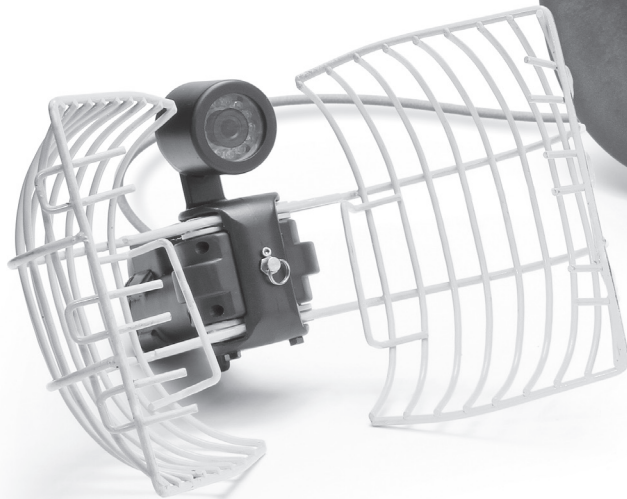

## In The Package

The following items come with your Underwater Viewing System.

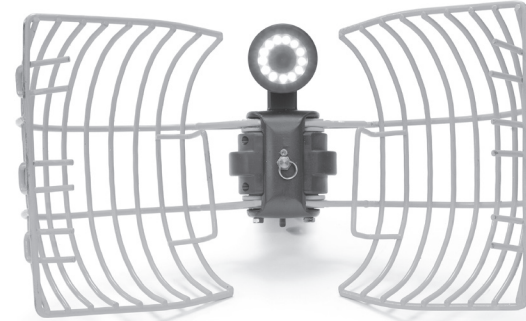

Camera and retrieval claw



7" HD LCD monitor



Sun shield

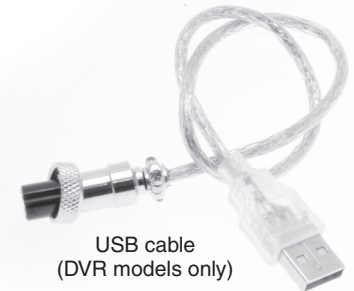

USB cable  
(DVR models only)



Charger battery and carry case

Warranty Card

Stop Card

Manual

## About Your Aqua-Vu System

This Aqua-Vu Underwater Viewing and Retrieval System features a 1/3" Sony CCD color camera, 7" HD LCD Monitor and the remote controlled "Claw". It also features high intensity LED lights for operation in low light conditions.

## Product Safety

Always keep camera cable away from ice augers, propellers, etc.

Keep the monitor and camera away from portable heaters, radiators or other heat generating equipment.

Avoid wedging camera in rocks, roots, submerged trees, or underwater debris.

Do not store unit in damp places.

Do not attempt to disassemble the waterproof casing of the camera or monitor. This voids the warranty.

## Using the Stabilizing Fin

The Aqua-Vu Claw includes a stabilizing fin to maintain camera orientation while walking along the side of a pier or your boat. The Claw IS NOT designed to be used from a moving boat.

Attach the stabilizing fin by sliding the fin onto the camera housing. Be sure to orientate the fin correctly. Use a 3mm hex wrench to tighten the bolt.

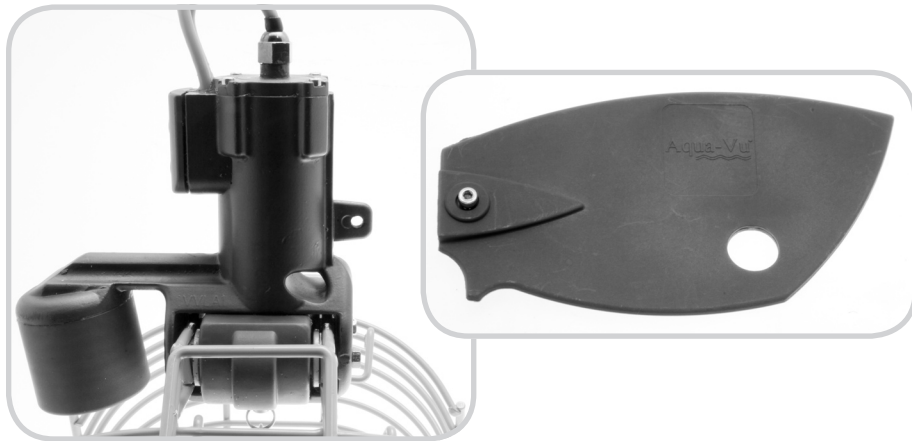

## Powering the Aqua-Vu

This Aqua-Vu comes with two rechargeable 12 volt batteries wired in series to deliver the required 24 volts to the motor. The batteries are replaceable but not user serviceable. There is no need to add water or electrolyte.

## Charging the Battery

To charge the battery use the battery charger that came with your Aqua-Vu. Recharge the battery by attaching the charger to the battery. Plug the charging unit into a 120 VAC power source.

**Note:** The battery charger has an LED charge status indicator. With the charger powered and attached to the auxiliary power/charging port, you will see either a red or green LED lit.

Red indicates a drained battery, or a drained battery that is being charged.

Green indicates that the battery is fully charged and ready to use; disconnect the battery from the charger.

## Battery Care

Follow these simple rules for prolonged battery life and efficient use of your Aqua-Vu Underwater Viewing System:

Fully charge the battery as soon as possible after purchase.

Recharging is recommended after every use. When not in use, recharge every six months.

Store battery between 30 and 70 degrees F. Service life is shortened by temperatures above 80°F and below 0°F.

Charge battery according to proper procedures. Continuous overcharging or undercharging is detrimental.

## Over Charging

The charger provided with this Aqua-Vu will not overcharge the battery in most cases. Do not charge for more than 24 hours. If you do not use our recommended charger avoid using a charging system with more than a 2-amp output. At too-high charging rates, a battery progressively heats up and may be ruined in a few hours.

## Under Charging

Batteries stored too long in discharged conditions accept current at far-below-normal rates during charging. A battery may accept an increasing amount of current until a normal level is reached. However, some discharged batteries never recover. And discharged batteries that freeze may be permanently damaged.

## Using the Aqua-Vu Controls

The Aqua-Vu has the following controls located below the monitor.

**On/Off** — The ON/OFF Power button turns the monitor and camera On or Off. After tuning on the Aqua-Vu, the screen may take several seconds to appear.

## "Claw" Operation

The center button on the handle is used to open and close the claw. The motor on the claw is strong. Use care when picking up delicate items.

## Trouble Light

On the bottom of the monitor housing is a trouble light. The switch on the left is used to turn the light off and on.

## Viewing /Recording Images on the Monitor

If images are difficult to see on the monitor there are several things you can try. First attach the sun shield by stretching the sun shield over the monitor and secure with the hook and loop strap. Aside from the sun shield there are several menu options you can adjust on the monitor itself.

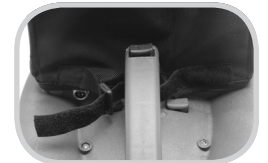
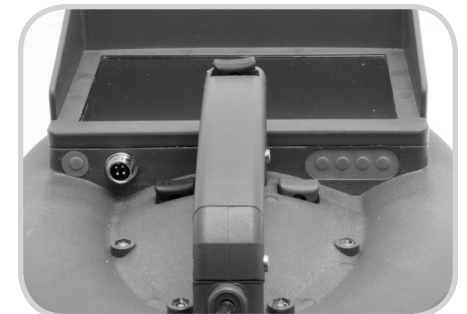



### Units without DVR

Use the A button to bring up the main menu and exit, use the B button to select and the up and down arrow buttons to adjust.



### Monitor Menu Functions

Press the B button to access the monitor menu. Once the menu is displayed press the B button to advance through the options. Use the A button on the far left side and A button to adjust the value. Use the up arrow to exit the setup menu.

### DVR Operation (DVR models only)

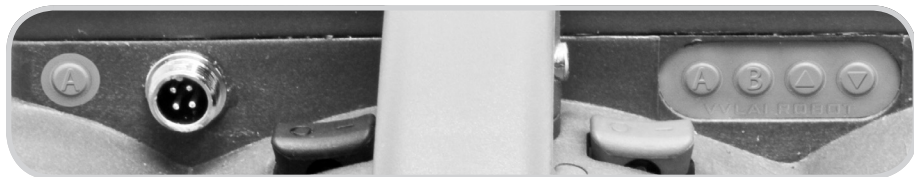

### Record Video

Press the A button on the far left side to start and stop recording. The record time will be shown in the lower left hand corner while the unit is recording. You can set the maximum record length in the monitor menu.

### Record Picture

Press the down arrow button to take a snap shot. The word “recording” will briefly be displayed on the monitor while recording a snap shot.

### Video Playback

From live view press the A button to access recorded video. Press the A or A button on the far left side key to navigate through recorded videos. Press the B button to start and stop playback. Press the Down arrow to prompt for delete, when prompted press the Down arrow again to confirm and delete. Caution! After deleting, the next recorded video appears asking you to confirm deletion. Use the A or A button on the far left side to navigate away to avoid accidentally deleting a video you would like to keep. Press the up arrow to exit playback mode.

### Picture Playback

From live view press the up arrow to access picture playback. Press the A or A button on the far left side to navigate through recorded images. Press the Down arrow to prompt for delete, when prompted press the Down arrow again to confirm and delete. Caution! After deleting, the next recorded image appears asking you to confirm deletion. Use the A or A button on the far left side to navigate away to avoid accidentally deleting a image you would like to keep. Press the up arrow to exit playback mode.

### Transferring Stored Files

Using the included USB cable attach the monitor to your computer. Turn the camera on. Power must be supplied to the camera and it must be turned on for your computer to recognize the new hardware. After your computer finds the camera you can navigate to the files stored on the camera. You can copy and delete images. Videos are recorded in AVI format.

### Frequently Asked Questions

Question	Answer
How far can I see?	Naturally, the clearer the water, the farther you can see. As a general rule, in water the camera can see twice as far as the human eye — meaning that if you can see 3 feet down you will be able to see approximately 6 feet in front of the camera. But this is just a rule of thumb. Water bodies vary in water clarity and other characteristics. For studying bottom structure, 2 feet of visibility is sufficient for underwater viewing, though in very clear water, it is possible to see up to 30 feet or more.
When do I use the lights?	The Aqua-Vu lights in your Aqua-Vu camera are designed for use in low-light conditions. The lights are automatic and can not be turned on or off by the user.
How do I steer the camera?	For viewing in the direction of travel, attach the stabilizer fin to the camera housing. Slowly walk along the pier or side of your boat alongside the structure you intend to view. The Claw is not designed to be trolled or used from a moving boat. With fin attached, the camera will face in the boat's direction of travel. If you're facing and moving forward, so will the camera; it will show you the underwater terrain in front of you. The stabilizer fin always keeps the camera tracking straight, so long as you're moving.
Can I splice the camera cable to obtain more length?	No. Attempting to splice in additional cable violates the waterproof integrity of the camera and cable. This will void your warranty.
Can I use my Aqua-Vu in saltwater?	Yes. All Aqua-Vu cameras are saltwater-rated, constructed with stainless steel hardware and materials that are impervious to corrosion. We recommend rinsing salt water off camera using clean water and a soft cloth after every use.
Will my unit work in subfreezing conditions?	Aqua-Vu systems are designed to operate at temperatures ranging from -10 to 120 degrees F. Expect your battery life to decrease in cold conditions.
How wide is the camera's angle-of-view?	Your camera lens has a viewing angle of 92 degrees. At 4-1/2 feet in front of the camera you will be viewing an image approximately 6 feet wide.
Is Aqua-Vu legal?	To our knowledge there are no restrictions that regulate the use of Aqua-Vu underwater viewing systems.

## Troubleshooting

Problem	Cause	Solution
Nothing happens (Screen fails to light up) when the unit is turned on.	Battery not connected.	Properly connect the battery: red to red, black to black.
	Battery not charged	Attach battery charger and charge battery for 12 - 24 hours.
I lowered the camera to the bottom but can't see anything.	The camera may be buried in muck!	Raise the camera off the bottom.
	The water might be very murky.	Turn the camera lights On for enhanced viewing in low-light conditions.
The camera seems to work above water but not below.	The camera is not positioned correctly.	Try lowering camera until it hovers just above bottom. You should now be able to make out the outline of the lake bottom. Without the solid reference point of the bottom, the monitor may appear to look blank.
	The water clarity is poor.	What you see on the screen is directly related to water clarity. If the water is dirty, visibility will be limited. Again, try to keep the camera running a foot or less above bottom.
There is a nick in the camera cable.	Cable may have gotten snagged on a sharp surface.	See the "How to Obtain Service" section of this manual for instructions on replacing the camera.
The image on the screen has a dark margin around it or is blurry.	You're seeing on-screen symptoms of a weakening battery.	Charge the battery, install a charged battery or connect to an external battery.

## Warranty Information

### One Year Limited Warranty

Outdoors Insight, Inc. warrants this product to be free from defects in materials and workmanship for one year from the date of purchase. This warranty applies to customers who properly fill out and return the warranty card included with this manual. Failure to complete and return the warranty card voids the warranty. Outdoors Insight, Inc. will, at its sole discretion and without charging the customer, repair or replace any components that fail in normal use. Failures due to abuse, misuse, or unauthorized alteration, modification or repair are not covered. Cut camera cables and submerged monitors are not covered. Broken cable and/or monitor connectors will incur a service repair charge. The warranty is valid only for the original owner who purchases the unit from an authorized Aqua-Vu dealer.

A two year extended warranty is available through Outdoors Insight, Inc. You may purchase this warranty within 30 days of purchasing the unit by visiting [www.aquavu.com](http://www.aquavu.com) to print the form.

### How to Obtain Service

We want our products to provide you with a pleasant on-the-water experience. That means maximum customer satisfaction. If you have a problem with your Aqua-Vu unit please contact the Outdoors Insight's toll free number at (866) 755-6303 for a Return Authorization Number (RA#). No service returns will be accepted without this pre-return authorization number, which must be clearly marked on the outside of the package. Outdoors Insight, Inc. retains the exclusive right to repair or replace the unit at its discretion.

The customer is responsible for shipping costs associated with returning the unit to Outdoors Insight, Inc. Outdoors Insight, Inc. will pay for shipping the repaired unit back to the customer while it is still under one-year warranty. All out of warranty services will be charged a fee for service and shipping which must be paid in advance. After obtaining a Return Authorization number, the unit should be securely packed and shipped "pre-paid freight" and insured to Outdoors Insight, Inc. It is the consumers' full responsibility to track their products sent out in the mail or other forms of delivery service. Outdoors Insight Inc. will not be liable for lost packages sent out in the mail. Unless specified otherwise, do not include battery or other accessories when returning the Aqua-Vu unit for repair. Outdoors Insight, Inc will not be responsible for lost or damaged accessories. Please allow a minimum of 10 business days prior to calling on the status of your repair.

Outdoors Insight  
34076 County Road 3  
Crosslake, MN 56442  
1-866-755-6303

RA# \_\_\_\_\_

Note: The RA number must be clearly marked on the outside of the package